

- 1
- 2
- 3
- 4
- 5
- 6
- 7
- 8
- 9
- 10
- 11
- 12
- 13
- 14
- 15
- 16
- 17
- 18

TYPES

- Type **A**: without sealing washers
- Type **B**: with sealing washers

Main specifications

- AISI CF-8 stainless steel
- Sandblasted matte finish
- Sleeve bearing
- Plastic (PTFE)
- Carriage bolt DIN 603
- Stainless steel
- Cap nuts DIN 917 / Washers
- Stainless steel
- Seals
- Sealing washers
- Plastic (Polyacetal POM)
- Spacer ring
- Silicon, 40 ... 60 Shore A

FEATURES AND APPLICATIONS

Flanged linear actuator connectors GN 163.15 are based on flanged connector clamps. The additionally provided mounting holes are used to connect to the drive key of a linear actuator. Bores with the designation **G** are equipped with sleeve bearings.

With the screw location **z**, the play of the guide bore d1 can be adjusted or the linear actuator connectors can be clamped after adjustment. Type B is equipped with seals at the screw locations.

For quick clamping without tools, the cap nut can be replaced by the adjustable hand levers GN 911.3 (see page).

ACCESSORY

Adjustable Hand Levers GN 911.3 (see page).

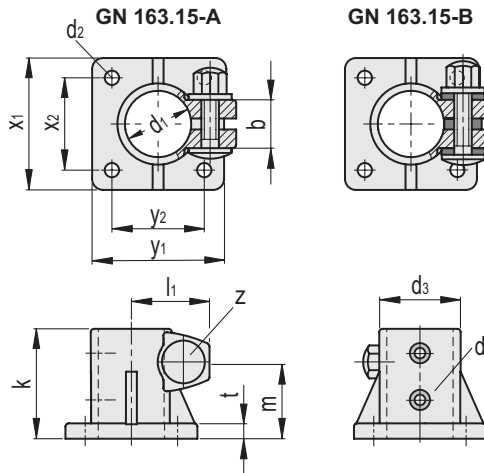
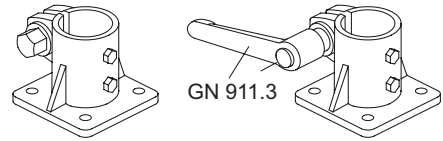

GN 163.15-A

Code	Description	d1 Bore with sleeve bearing	d2	d3	d4	b	k	l1	m	t	z	x1	x2	y1	y2	z Clamping kit	⚖️
GN.48951	GN 163.15-G30-A-4	G 30	6.5	37	M 4	22	50	36	35	6.5	M 8	60	42	60	42	GN 911.3-63 / GN 911.3-78	265
GN.48955	GN 163.15-G50-A-4	G 50	10.7	60	M 6	30	85	48.5	60	9	M 10	105	74	105	74	GN 911.3-78 / GN 911.3-92	1168

GN 163.15-B

Code	Description	d1 Bore with sleeve bearing	d2	d3	d4	b	k	l1	m	t	z	x1	x2	y1	y2	z Clamping kit	⚖️
GN.48953	GN 163.15-G30-B-4	G 30	6.5	37	M 4	22	50	36	35	6.5	M 8	60	42	60	42	GN 911.3-63 / GN 911.3-78	265
GN.48957	GN 163.15-G50-B-4	G 50	10.7	60	M 6	30	85	48.5	60	9	M 10	105	74	105	74	GN 911.3-78 / GN 911.3-92	1168

Tube connectors